



Avoiding hazards when working with roll-off waste containers

Drivers who load and transport roll-off waste containers are at risk of injury from containers that have been poorly maintained or improperly loaded.

Before loading the container onto the truck

- Back the truck slowly up to the container, and keep the lifting point centred between the rails of the truck.
- Walk around the container and inspect the condition of hinges, doors, opening devices, the door-locking mechanism, and the load hook-up point. Ensure that all door safety chains are in place and usable.
- Check the load's height, which could interfere with tarping.
- Estimate the load's weight and distribution to ensure they are acceptable.
- Call your supervisor for instructions if you have any concerns about the container's condition or its load.
- Place the tarp over the container while the container is still on the ground to avoid working at heights.

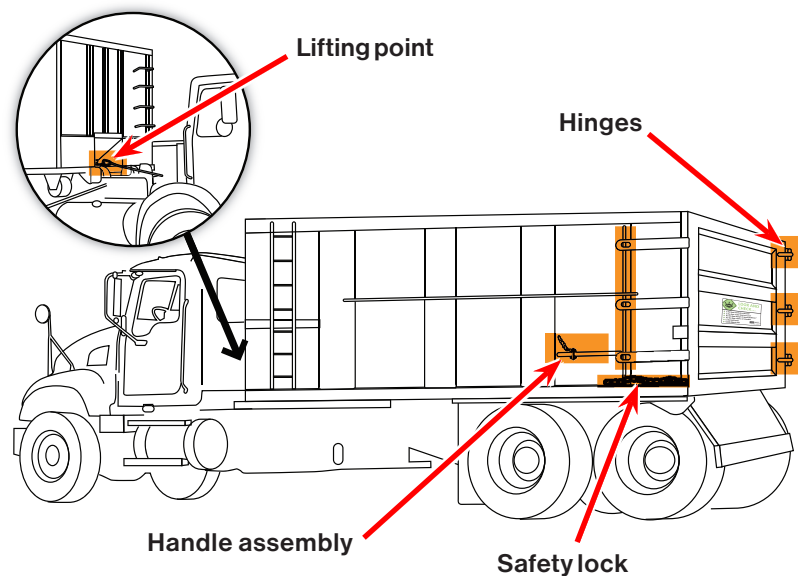

Loading the container onto the truck

- Attach the hook to the container, and ensure that the safety clip on the hook is locked in place.
- Lift the container slowly, and lower the truck bed to reduce the angle at which the bin is being lifted.
- Adjust the steering to ensure the truck is pulled straight under the bin.
- Stop lifting if the container seems too heavy or unbalanced.
- Once the container is on the truck, secure it properly with the safety chains.

Preparing to empty the container

- Once the truck is in position to dump, check for objects that have shifted during travel and may fall.
- Stand in a safe position off to one side of the container to open the door handle. The handle may be under pressure and may spring out. **Do not stand in front of it.**
- Stay in a safe position while you open the door. The door may swing out.
- After opening the door, use the chains to pull it fully open and to secure the door to the side of the container.

Project: _____ Address: _____

Employer: _____ Supervisor: _____

Date: _____ Time: _____ Shift: _____

Number in crew: _____ Number attending: _____

Other safety issues or suggestions made by crew members:

Record of those attending:

| Name: (please print) | Signature: | Company: |
|----------------------|------------|----------|
| 1. | | |
| 2. | | |
| 3. | | |
| 4. | | |
| 5. | | |
| 6. | | |
| 7. | | |
| 8. | | |
| 9. | | |
| 10. | | |
| 11. | | |
| 12. | | |
| 13. | | |
| 14. | | |
| 15. | | |

Manager's remarks: _____

Manager: _____ Supervisor: _____

(signature)

(signature)



WORKING TO MAKE A DIFFERENCE
worksafebc.com